



FLUID APPLIED BUR - MODIFIED BITUMEN ROOF RENOVATION

- ✓ AVAILABLE ACROSS THE US & CANADA WITH LOCAL SALES & PROJECT SUPPORT
- ✓ APPROVED LOCAL CONTRACTORS ACROSS THE US & CANADA
- ✓ SO MUCH MORE THAN A LIQUID APPLIED ROOF COATING
- ✓ PERFORMANCE COMMENSURATE TO ROLL SHEET ROOFING
- ✓ THE GOLD CLASS OF PROTECTION

TYPICALLY INSTALLED OVER A VARIETY OF ROOF SUBSTRATES INCLUDING BUR / MODIFIED BITUMEN

HIGHER RESISTANCE TO EXTREME WEATHER CONDITIONS. AVAILABLE IN INDUSTRY LEADING HAIL RESISTANT CONFIGURATIONS.

REDUCES IMPACT ON OCCUPANCY DURING INSTALLATION.

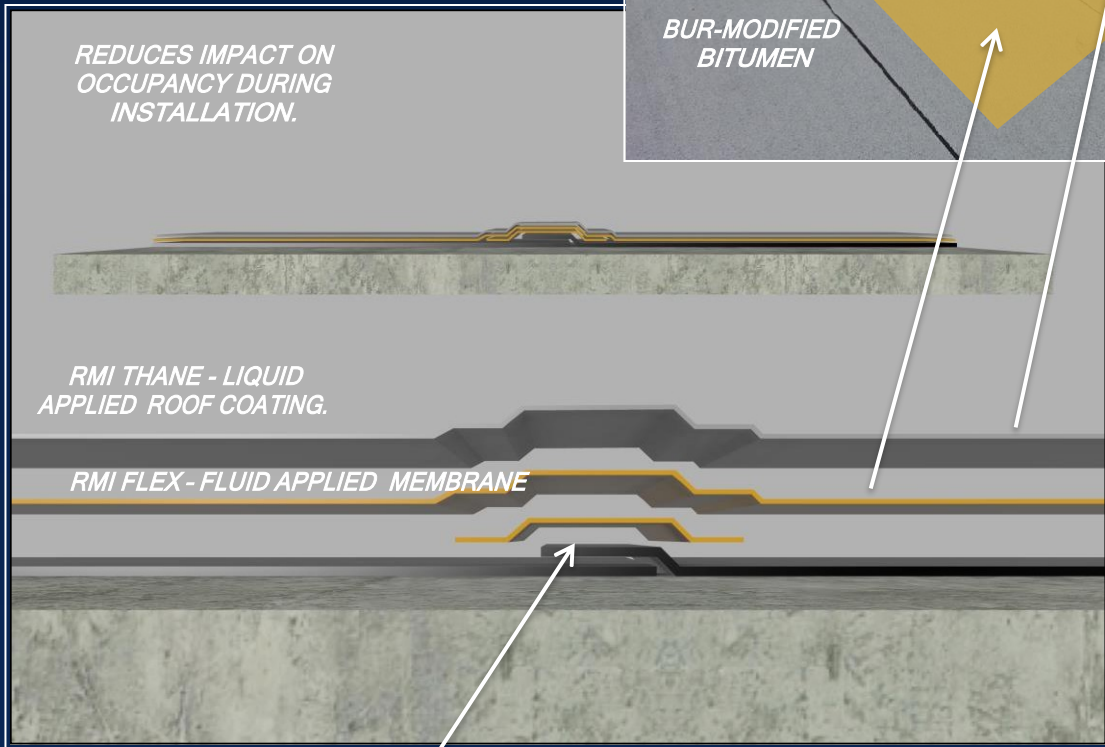
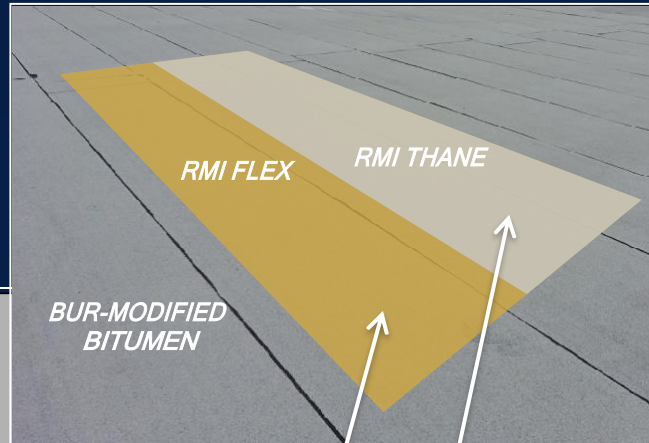

RMI THANE - LIQUID APPLIED ROOF COATING.

RMI FLEX - FLUID APPLIED MEMBRANE

RMI FLEX DOES NOT REQUIRE FABRIC REINFORCEMENTS AS MANY OTHER ROOF COATING SYSTEMS.

SPRAY OR ROLL APPLICATIONS

FINALLY (WELL FOR AT LEAST THE LAST 35 YEARS) A FLUID APPLIED ROOF SYSTEM WITH COMMENSURATE PERFORMANCE AS SINGLE PLY ROOF SYSTEMS. NO LANDFILLS, ENERGY EFFICIENT AND ONE OF THE MOST HAIL RESISTANT ROOF SYSTEMS. PERIOD!



FLUID APPLIED BUR - MODIFIED BITUMEN ROOF RENOVATION

- ✓ AVAILABLE ACROSS THE US & CANADA WITH LOCAL SALES & PROJECT SUPPORT
- ✓ APPROVED LOCAL CONTRACTORS ACROSS THE US & CANADA
- ✓ SO MUCH MORE THAN A LIQUID APPLIED ROOF COATING
- ✓ PERFORMANCE COMMENSURATE TO ROLL SHEET ROOFING
- ✓ THE GOLD CLASS OF PROTECTION

RMI THANE - HIGH PERFORMANCE LIQUID APPLIED WEAR SURFACE ROOF COATING IS ON TOP WHERE IT BELONGS

--32F - + 100 F REAL WORLD INSTALLATION TEMPS. COMPARE THAT TO OTHER SYSTEMS

100% SOLIDS - FLUID APPLIED BASE MEMBRANE . NO SHRINKAGE - 850+% ELONGATION @ -32F. COMPARE TO OTHER SYSTEMS

FLEX FLUID APPLIED BASE MEMBRANE . NO LIMITATION ON SINGLE PASS MIL THICKNESS. TYPICAL 5-25 MINUTE SET UP. COMPARE THAT TO OTHER SYSTEMS

RMI FLEX DOES NOT REQUIRE FABRIC REINFORCEMENTS UNLIKE TYPICAL LIQUID APPLIED ROOF COATING SYSTEMS

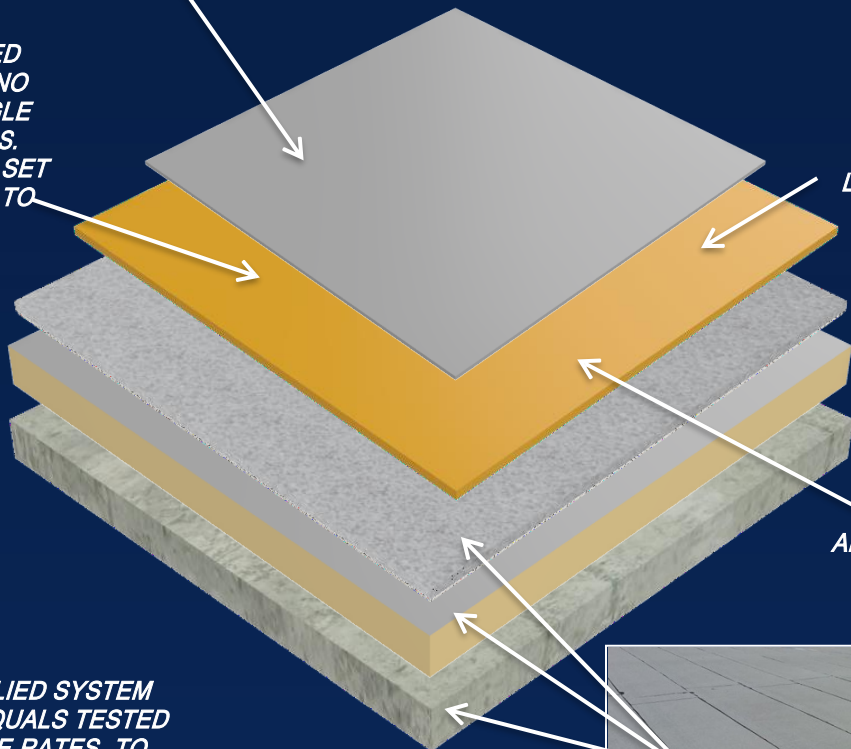

SAME DAY BASE AND SURFACE COAT APPLICATIONS. COMPARE THAT TO OTHER SYSTEMS

RMI FLEX - 100% SOLIDS FLUID APPLIED MEMBRANE

FINISHED APPLIED SYSTEM THICKNESS EQUALS TESTED PERFORMANCE RATES TO ACHIEVE < 1 PERM (PERMEANCE) . ASK ANOTHER SYSTEM MFG. TO PUT THAT IN WRITING



FINALLY (WELL FOR AT LEAST THE LAST 35 YEARS) A FLUID APPLIED ROOF SYSTEM WITH COMMENSURATE PERFORMANCE AS ROLL ROOF SYSTEMS. NO LANDFILLS, ENERGY EFFICIENT AND ONE OF THE MOST HAIL RESISTANT ROOF SYSTEMS. PERIOD!



Fluid Applied Roof Membrane / Liquid Applied Roof Coating ?

Fluid Applied Roof Membrane: Its purpose is to provide a low Permeance (<0.5 perm) (Non breathable) water tight / waterproof foundation barrier application of the roof system. Depending on the product composition it can be used as both foundation and surface application.

Class I: < 0.1 Perm - Fluid Applied Membranes (Waterproofing) Includes RMI-Flex

Class II: <1.0 perm Fluid Applied Membranes (Polyurea, PUR, RMI-Flex) Typical Roll Sheets (Mod Bit, PVC, TPO, EPDM, Hot Asphalt)

PERMEANCE = Water trying to enter a roof from the top surface



RMI FLEX - 100% SOLIDS FLUID APPLIED MEMBRANE

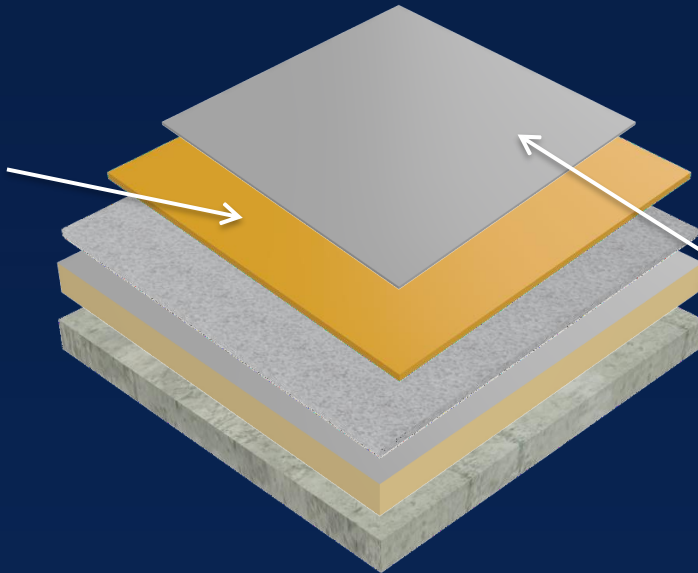

RMI THANE - HIGH PERFORMANCE LIQUID APPLIED WEAR SURFACE ROOF COATING

PERMEABILITY = Transfer of water vapor from a liquid applied roof coating



Liquid Applied Roof Coating: A coating whose purpose is to provide a sacrificial wear surface over a roof system. Typically a higher Permeance (>1 perms) (Breathable). Depending on individual product composition it can be used at higher rates of application as both foundation and surface application to achieve a Permeance of <1 perm)

Class III: >1 to ≤ 10 perm. Typically Emulsions, Acrylics, Silicones, Urethanes, EPDM Coatings.

10 > perm (Vapor Permeable Membrane) Interior Drywall



When **PRODUCT PERFORMANCE & SUPPORT Matters®**

FLUID APPLIED BUR - MODIFIED BITUMEN ROOF RENOVATION



SURFACE PREPARATION



RMI FLEX

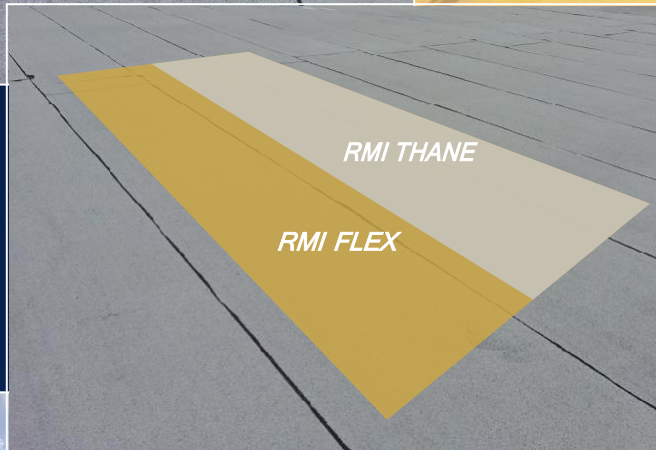

RMI THANE

RMI FLEX



RMI MECHANICAL DUCTWORK RESTORATION



RMI THANE